



il Classico



***Tosco*cornici**
LE PORTE SECONDO NOI

Catalogo



Toscocornici

Catalogo Classico
Classic Catalogue

AZIENDA <i>The Company</i>	04
ESSENZE <i>Essences</i>	06
FINITURE <i>Wood Finishes</i>	07
ALESSANDRIA <i>baseSTCS</i>	08
PUGLIA <i>baseSTCVS</i>	14
TOSCANA <i>baseSTC</i>	18
TAORMINA <i>300-5V</i>	20
MANTOVA <i>200</i>	22
PIENZA <i>base3TU</i>	28
PIENZA2 <i>base3TU2</i>	29
SIENA <i>base</i>	30
GENOVA <i>600-6V</i>	32
LAGUNA <i>300GRB</i>	34
CAMPANIA <i>baseSTC1V</i>	36
EMILIA <i>baseSTC2BL</i>	37
RAGUSA <i>200FL5B</i>	38
FAENZA <i>200FL</i>	40
ROMA <i>200FL6B</i>	43
AMERICA <i>100</i>	44
ARIZONA <i>100-3B1</i>	47
VIENNA <i>100-CPTQ</i>	50
POTENZA <i>200-OV</i>	54
MATERA <i>200-OV 1V</i>	58
PICCADILLY <i>100-C</i>	60
CANTERBURY <i>100-C3B</i>	61
LONDON <i>100-C3B1</i>	62
OLD CITY <i>700-C2B</i>	64
LIVERPOOL <i>400-CTQ</i>	65
OXFORD <i>700-CTS</i>	66
SIENATS <i>baseTS</i>	67
PORTE REI 30	68
PORTE A LIBRO	72
MODELLI PORTE <i>Door Models</i>	76
VERSIONI DISPONIBILI <i>Versions available</i>	79
SCHEDE TECNICHE <i>Technical Datasheets</i>	80
FERRAMENTA <i>Accessories</i>	82
SUPPORTI VENDITA <i>Helper to choose the best</i>	83

MARCHI DI FABBRICA

Tutti i nomi dei prodotti evidenziati o meno o che prevedono l'apposizione di marchi di fabbrica sono marchi di Toscocornici Porte.

Tutti gli altri marchi come AGB®, KOBLENZ®, BONAITI, SICMA®, MANDELLI®, ERGON®, OTLAV® sono proprietà dei rispettivi possessori. Nessuno di questi marchi può essere utilizzato con riferimento ad altri prodotti o servizi così da generare confusione per il cliente, o svilire o screditare i proprietari.

I diritti di utilizzazione sono esclusivi della ditta Toscocornici. E' vietata la riproduzione anche parziale a norma dell'Art. 90 L. 633/41.

TRADEMARKS

All product names highlighted or less or which provide for affixing trademarks are trademarks of Toscocornici Porte.

All other brands such as AGB®, KOBLENZ®, BONAITI, Sicma®, MANDELLI®, ERGON®, OTLAV® are property of their respective owners. None of these marks may be used with reference to other products or services so as to create confusion for the customer, or demean or disparage owners.

The use rights are excluded you of company Toscocornici. The partial reproduction also, in compliance with the Art. 90 L. 633/41.

AZIENDA

The Company



La Toscocornici nasce negli anni '70 per volontà di Arturo Bove; la presenza dell'azienda nel cuore della Val di Chiana, famosa per la lavorazione del legno, fornisce l'humus ideale per lo sviluppo di Toscocornici, che da oltre 30 anni, passando nelle mani del figlio Stefano, fa del legno la propria professione e della porta per interni in massello Toscocornici, un prodotto di altissimo pregio.

La passione per la lavorazione del legno, tramandata all'interno della famiglia Bove, oltre alla soddisfazione del cliente, negli anni ha permesso lo sviluppo dell'azienda Toscocornici secondo due precise direzioni strategiche: consolidamento nel tempo della propria posizione sul mercato e sviluppo della produzione verso le nuove esigenze tecniche e di design.

La porta in massello Toscocornici deve il proprio successo ad una serie di importanti fattori. Innanzitutto la scelta del personale, altamente qualificato ed in grado di trasmettere alla porta toscocornici la propria passione ed abilità.

I macchinari, sempre più moderni ed in grado di produrre soluzioni sofisticate, studiate per andare incontro ad esigenze strutturali in continua evoluzione.

La dinamica gestione aziendale che ha generato una capillare diffusione di nostri rivenditori su tutto il territorio nazionale.

La posizione geografica dell'azienda e la vicinanza di un importante nodo autostradale, per avere un'ottima gestione logistica facilitando la puntualità delle consegne.

Per questi motivi, oggi possiamo affermare che il successo della Toscocornici è il frutto di una concreta e mirata sinergia vincente.

Nelle nostre porte troverete l'esperienza, l'amore per il dettaglio, il rispetto per le nuove esigenze di sicurezza; l'attenta selezione della materia prima, che ci permette di proporre ai nostri clienti il meglio di ciò che la natura offre; i processi primari di lavorazione, la cura delle finiture e la perizia con cui sono effettuati i controlli qualità, sono alla base del nostro marchio di garanzia. Nella nostra azienda la porta non è concepita solo come elemento tecnico e di chiusura ma come vero e proprio complemento d'arredo. Bella, robusta, destinata a durare nel tempo, adatta alla casa in stile o moderna. Noi vogliamo che la nostra porta sia capace di stimolare la vostra idea di casa andando incontro ad ogni esigenza e gusto architettonico. La scelta delle diverse essenze e la lavorazione nei particolari vogliono trasmettere alla porta Toscocornici eleganza, armonia, personalità. Nella nostra ricca collezione, la sobrietà del colore si combina all'eleganza della forma e alla raffinatezza del design in modo da aggiungere prestigio alle soluzioni di arredo.

Il nostro personale specializzato sarà lieto di portarVi all'interno del mondo Toscocornici e guidarVi nella scelta ottimale per la vostra casa.



Arturo Bove founded Toscocornici in the early 70's; in that period Val di Chiana region had a flourishing development of the woodworking industry and Toscocornici has been growing in that favourable position for more than 30 years. Stefano, Arturo's son, is actually managing the company with the same passion for wood as his father. For this reason Toscocornici Porte are now considered as unique and prestigious products.

The customer satisfaction, the control of the company position on the market, the most recent manufacturing techniques and the research of the market trends have always been the family targets.

Toscocornici developed thanks to the careful selection of qualified and professional staff giving our doors a day by day experience so that we can offer high quality products. Our brand new production lines grant us the possibility to study the most appropriated solutions to satisfy any customers' request and our very active commercial management has found very good retailers all over Italy and finally the geographical position of the company and the proximity to one of the most important highway permit us to optimize the logistic and respect our lead time.

For the above mentioned reasons, we can easily say that our success is the fruit of a concrete, aimed and winning synergy

In our doors you will find all our experience, our love for details, the careful selection of the raw materials and the respect for the actual safety law requirements which allow us to offer our customers all the best natural material. The accurate working processes and quality controls are the fundamentals of our warranted brand.

Toscocornici do not produce doors only as a technical and closing element but as a real furniture complement. Nice, strong, lasting, we have studied our doors for classic or modern style.

We want to stimulate your imagination and give you the possibility to find any architectural solution. Our collection offers a very wide range of wood essences and the careful working processes give you the feeling of elegance, harmony and personality of each door.

The colours, the elegant shapes and the refined design are adding prestige to the furnishings solutions.

Our specialized staff will be glad to bring you inside Toscocornici world and suggest you to the best solutions for your home.

ESSENZE

Essences



ROVERE Oak

Legno molto diffuso in America Europa ed Asia. Può raggiungere anche i 30 mt di altezza, ma le sue caratteristiche tra cui la fibra e la sfumature del colore bruno possono variare a secondo della regione. Per la sua resistenza all'umidità è molto usato per ambienti esterni.
Mostly spread in America, Europe and Asia. It can reach 30 m of height, but it's fibre and tawny colour can vary from region to region. Thanks to its resistance to humidity, it is mainly used for external applications.



CASTAGNO Chestnut Tree

Il castagno, legno europeo, è di colore bruno chiaro molto durevole e resistente all'umidità. Ottimo per usi esterni, è usato per infissi, serramenti, pavimentazioni, telai, nonché per mobili. La sua venatura molto accentuata può variare dal fiammato al rigato.
The chestnut tree is a European wood. It's light tawny coloured, very durable and resistant to the humidity. It is recommended for external use. It is used for door and window frames, paving and for furniture. Its emphasized grain can vary from flamed to striped one.



TOULPIER Toulipier

Di provenienza americana, ha un colore giallo canarino con sfumature verdastre. Di fibra uniforme e dritta è un legno moderatamente rigido e molto resistente alle sollecitazioni. Per le sue caratteristiche è un legno adatto a numerosi tipi di impiego.
Coming from America, it's colour is canary yellow with green shadings and it's fibres are uniform and straight. It is moderately rigid and very resistant to sollicitations. Thanks to it's own characteristics, it is appropriated for many working processes.



ALDER Alder

È un legno usato prevalentemente per arredamenti e parti per mobili. Di provenienza americana, l'Alder di colore rosato pallido tendente al bianco, ha una tessitura fine e una fibratura dritta.
One of the most popular wood in the furniture industry. Coming from America it has a fine weaving and straight fibre. Alder is quite pale pink tending to the white.



PINO Pine

Legno europeo di colore bruno chiaro, tessitura meda e fibratura dritta. Ottima resistenza all'umidità e abbastanza durevole. Molto utilizzato nei serramenti e in generale all'esterno, nonché nei mobili.
European wood, light tawny coloured, with medium weaving and straight fibre. It is very resistant to the humidity and quite durable. Mainly used for exterior applications like windows and door frames and in the furniture industry.



KIT Kit

Soluzione ideale per tutti coloro che la porta se la vogliono montare: otterranno il massimo in rapidità di consegna e risparmio nel costo d'acquisto.
Ideal solution for customers who want to assemble their own door: they will obtain the quickest delivery and savings in purchasing cost.

FINITURE

Wood Finishes



[1955] Castagno Base [1487] Castagno Scuro [2901] Castagno Invecchiato Extra [3502] Castagno Base Opaco-5 [5555] Castagno Scuro Cas-001 [5426] Rovere Base [3513] Rovere Scuro

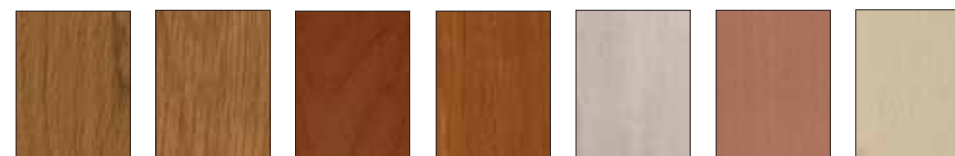

[5315] Rovere Naturale [5531] Rovere Naturale Opaco-5 [1418] Alder Scuro [1334] Alder Chiaro [1593] Alder Accero [5178] Faggio Base [5433] Toulipier Laccato Screpolato



[5497] Toulipier Laccato Pennellato [3340] Toulipier Base con Sfumatura [1970] Toulipier Base senza Sfumatura [2808] Toulipier Invecchiato Extra [3413] Toulipier Ciliegio



[1844] Toulipier Invecchiato Extra Opaco-5 [5796] Toulipier Laccato Anticato [5190] Toulipier Mogano [5554] Toulipier Accero [5321] Toulipier spazzolato Anticato



[5117] Pino Spazzolato Anticato [3415] Pino Base [3416] Pino Miele [2810] Pino Ciliegio [5503] Pino Invecchiato Extra Op-5 [5541] Pino Superbianco



GREZZO Raw Doors

Quando non c'è tempo ma si desidera comunque personalizzare con proprie tinte la porta, questa è la risposta giusta. This is the right solution when you have got no time but you want to personalize the door with your own colours

Essendo immagini fotografiche, i colori si ritengono puramente indicativi.
Being photographic images, the colors are thought indicated pure to you

Inoltre si eseguono finiture con codici RAL.
Moreover finishes with codes RAL are execute

ALESSANDRIA

baseSTCS

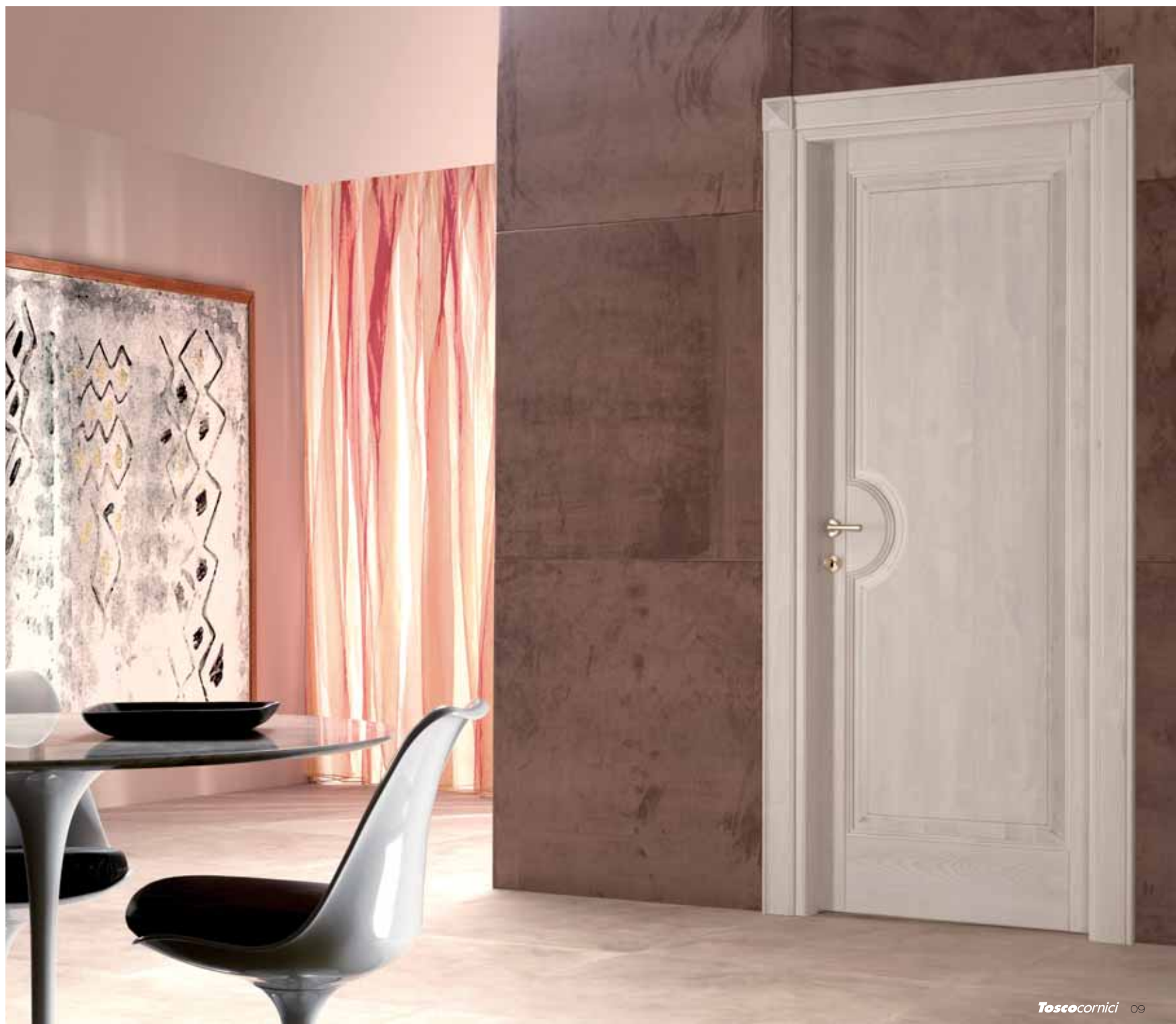

GRUPPO
baseSTC



CODICE
baseSTCS

ESSENZA
elder

FINITURA
elder acero

TIPO
tipo 1



TELAIO
standard



COPRIFILO
sagornato spoolate



ACCESSORI
elementi



MANIGLIA
mandelli Sori

ALESSANDRIA

baseSTCS



Decisamente bella e rigorosa. In questa porta si mantiene costante la tensione creativa tra la cultura della produzione e la cultura del design, preferibilmente moderno.

Beautiful and definitively rigorous style. Creativity and production rigour are under the eyes. This prestigious door is suggested for modern rooms.

GRUPPO
baseSTC



CODICE
baseSTCS

ESSENZA
tulipier

FINITURA
tulipier allegro

TIPO
tipo 1



TELAIO
standard



COPRIFILO
liscio



MANIGLIA
n.d.



ALESSANDRIA

baseSTCS



Una porta molto curata in tutte le fasi di progettazione, lavorazione e finitura. Lo stipite con capitello è un prezioso elemento decorativo ispirato al repertorio neoclassico. Il gusto eclettico di questa porta conferisce eleganza dandy al nostro ambiente.

All the possible care of Toscoconici in each working phase and finish of this door. The jamb with capital is a precious decorative element inspired to the neoclassic repertory. An eclectic taste of this door gives a dandy elegance to your room.

GRUPPO
baseSTC



CODICE
baseSTCS

ESSENZA
alder

FINITURA
oklar scuro

TIPO
tipo 1



TELAIO
standard



COPRIFILO
liscio



ACCESSORI
capitello, finiti
zoccoli



MANIGLIA
n.d.



PUGLIA

baseSTCVS



Una porta che arreda il tuo tempo. Sofisticata, vi introduce discretamente, con il suo raggio di luce stilizzato, nel luogo da voi scelto. Il rovere aggiunge resistenza e solidità a questa perfetta fusione tra modernità e tradizione.

A door furnishing your time. Sophisticated, introducing you softly with its stylized beam of light, in the room you have chosen. Oak adds resistance and solidity to this perfect fusion of modern and traditional style.

GRUPPO
baseSTC



CODICE
baseSTCVS

ESSENZA
rovere

FINITURA
rovere base

TIPO
tipo 2



TELAIO
bombato



COPRIFILO
bombato



VETRO
satinato bianco

MANIGLIA
sioma derby



PUGLIA

baseSTCVS



GRUPPO
baseSTC



CODICE
baseSTCVS

ESSENZA
loulper

FINITURA
loulper acero

TIPO
tbo 2



TELAIO
bombato



COPRIFILO
bombato



VETRO
satinato bianco

MANIGLIA
sioma derby

TOSCANA

baseSTC

GRUPPO
baseSTC



CODICE
baseSTC

ESSENZA
toulprier

FINITURA
toulprier laccato
ral 9010

TIPO
tipo 1



TELAIO
standard



COPRIFILO
liscio



MANIGLIA
n.d.



Telaio e coprifiло bombato
Frame rounded



GRUPPO
baseSTC



CODICE
baseSTC

ESSENZA
alder

FINITURA
alder scuro

TIPO
tipo 2 con bugna



TELAIO
bombato



COPRIFILO
liscio



MANIGLIA
sirma derby

Toscana, come le radici della tradizione artigianale di Toscoconrnici. L'essenzialità nelle linee, le geometrie pulite e sincere unite alla particolarità del pannello bugnato, del telaio bombato donano carattere schietto alla porta.

Toscana, like the traditional artisan roots of Toscoconrnici. Essential lines, genuine and clean geometries mixed with ashlar panels and cambered frames and staff bead's giving a really plain aspect to the door.



TAORMINA

300-5V

GRUPPO
base



CODICE
300-5V

ESSENZA
alder

FINITURA
alder scuro

TIPO
tipo 2



TELAIO
bombato



COPRIFILO
fiscio



VETRO
satinato bianco

MANIGLIA
sirma darby

GRUPPO
base



CODICE
300-5V

ESSENZA
alder

FINITURA
alder scuro

TIPO
tipo 2



TELAIO
bombato



COPRIFILO
bombato



VETRO
satinato bianco

MANIGLIA
sirma darby

Una porta solare che vi abbraccia nel suo caldo fascio di luce. Telaio e coprifili bombati, geometrie rigorose, essenziali. Una porta decisamente contemporanea che fa della luminosità il suo punto di forza.

A solar door with a warm light beam embracing you. Rounded frames and staff bead, rigorous and essential geometries. Definitely a contemporary door which main characteristic is the brightness.

MANTOVA

200

GRUPPO
base



CODICE
200

ESSENZA
toupier

FINITURA
toupier laccato antistato

TIPO
tipo 1



TELAIO
standard



COPRIFILO
liscio



ACCESSORI
capitello



MANIGLIA
mandelli Sot





GRUPPO
base



CODICE
200

ESSENZA
toupier

FINITURA
toupier base
con sfumatura

TIPO
tipo 1



TELAIO
standard



COPRIFILO
iscio



MANIGLIA
n.d.

Tonalità panna,
decorazione con
fiore, sofisticate
attenzioni per questa
porta che ispira
immediatamente
un senso di
raffinatezza.
Una porta resistente
e delicata insieme,
capace di introdurvi
in un ambiente
accogliente
e piacevole.

Cream tonality,
decoration with
flowers, sophisticated
attentions for this
door that immediately
inspires a sense of
refinement.
A resistant and
delicate door, able to
introduce you in
a pleasant
atmosphere.



GRUPPO
base



CODICE
200

ESSENZA
toupier

FINITURA
toupier laccato anticato

TIPO
tipo 1



TELAIO
standard



COPRIFILO
sagomato speciale



MANIGLIA
manicelli S91

MANTOVA

200

GRUPPO
base



CODICE
200

ESSENZA
toulpiér

FINITURA
toulpiér laccato antistato

TIPO
tipo 1



TELAIO
standard



COPRIFILO
liscio



ACCESSORI
elementi



MANIGLIA
mandelli S01

PIENZA

base3TU



Lavorazione tradizionale per questa versione a battente a madonna. La porta come andava nei casali rustici di un tempo: perfetta per la vostra casa di campagna. Colore caldo che rimanda ad un sapore antico. La tonalità più sicura rende questa porta particolarmente calda e vissuta.

Traditional working for this Madonna clapper version. The door you would have found in the Tuscan farms in the past. It's perfect for your cottage. A warm colour is sending you back to an old atmosphere. The dark tonality of this door gives a particularly warm and lived aspect to your room lived.

GRUPPO
base



CODICE
base3TU

ESSENZA
pino

FINITURA
pino base

TIPO
tpo 2



TELAIO
madonna



COPRIFILO
nessuno

MANIGLIA
sima country

PIENZA2

base3TU2



GRUPPO
base



CODICE
base3TU2

ESSENZA
toulpier

FINITURA
toulpier laccato
scrapolato

TIPO
tpo 2 con bugna



TELAIO
standard



COPRIFILO
bombato



ACCESSORI
capitello



MANIGLIA
sima country



Tonalità delicate, indicatissima per un ambiente classico; linee essenziali, semplici, per trasmettere immediatamente comfort della quotidianità.

Delicates tonalities, indicated for a classic atmosphere; essential, simple lines, immediately transmitting the day by day comfort.

- GRUPPO
base 
- CODICE
base
- ESSENZA
castagno
- FINITURA
castagno base
- TIPO
tipo 1 
- TELAIO
standard 
- COPRIFILO
sagomato 
- MANIGLIA
n.d.

Una porta amabile che si concilia facilmente in un'ambiente tradizionale. Geometrie essenziali, linea pulita che suggerisce immediatamente un senso di spaziosità.

A friendly door highly recommended for traditional atmospheres. Essential geometries, clean line that immediately suggesting a sense of space.

GRUPPO
base



CODICE
base

ESSENZA
pino

FINITURA
pino base

TIPO
tipo 1



TELAIO
standard



COPRIFILO
liscio



MANIGLIA
n.d.



La linea di questa porta in pino è valorizzata al massimo nella sua semplicità ed eleganza. Tonalità fresca e delicata.

The line of this door in pine and maximize its simplicity and elegance. Fresh and delicate shades.

GRUPPO
base



CODICE
base

ESSENZA
pino

FINITURA
pino allegio

TIPO
tipo 2



TELAIO
standard



COPRIFILO
liscio



MANIGLIA
sigma country



In questa porta domina il senso di freschezza; il colore del pino chiaro, attuale ci suggerisce un'atmosfera di intimità e di libertà.

You can feel a sense of fresh air dominating the atmosphere. The light and modern pine colour is suggesting freedom.

GRUPPO
base



CODICE
base-E

ESSENZA
pino

FINITURA
pino base

TIPO
tipo 3



TELAIO
standard



COPRIFILO
liscio



MANIGLIA
n.d.



GRUPPO
base



CODICE
base-E

ESSENZA
faggio

FINITURA
faggio base

TIPO
tipo 3



TELAIO
standard



COPRIFILO
liscio



MANIGLIA
sigma country



GENOVA

600-6V

GRUPPO
base



CODICE
600-6V

ESSENZA
castagno

FINITURA
castagno base

TIPO
tipo 2



TELAIO
standard



COPRIFILO
Isolo



VETRO
satinato bianco

MANIGLIA
sloma country



LAGUNA

300GRB



Una porta che non passa inosservata. La combinazione del legno scuro e delle geometrie di vetro colorato, la rendono particolarmente pregiata e rigorosa.

A door that you will notice. The combination of the dark wood and the coloured glass, make it particularly valuable and rigorous.

GRUPPO
base



CODICE
300GRB

ESSENZA
noce

FINITURA
noce scuro

TIPO
tipo 1



TELAIO
standard



COPRIFILO
liscio



VETRO
cattedrale colorato

MANIGLIA
n.d.





Adatta ad arricchire di luminosità il vostro ambiente. Linea squadrata che si ripete nelle geometrie della vetrata. Nell'insieme semplice ed essenziale.

Made to enrich your room with brightness; squared line that is repeated in geometries of the glass. So it is a simple and essential door.

Il rovere naturale è l'indiscusso protagonista di questa porta. Rifinita ulteriormente con un'allargatura su telaio. La resistenza e la durezza del rovere sono immediatamente percepite da chi si accosta a questa porta di pregio.

Natural oak is the protagonist of this door. More refined thanks to a widening on the frame. The resistance of the oak is immediately perceived from people who come near this value door.



GRUPPO
baseSTC



CODICE
baseSTC1V

ESSENZA
tulipier

FINITURA
tulipier base
con sfumatura

TIPO
tipo 1



TELAIO
standard



COPRIFILO
liscio



VETRO
 satinato bianco
+ incisioni

MANIGLIA
n.d.

GRUPPO
baseSTC



CODICE
baseSTC2BL

ESSENZA
rovere

FINITURA
rovere naturale

TIPO
tipo 1



TELAIO
standard



COPRIFILO
liscio



MANIGLIA
n.d.

RAGUSA

200FL5B



GRUPPO
base



CODICE
200FL5B

ESSENZA
castagno

FINITURA
castagno allegio

TIPO
tipo 2 con bugna



TELAIO
standard



COPRIFILO
liscio



MANIGLIA
mendell Sot

FAENZA

200FL

GRUPPO
base



CODICE
200FL

ESSENZA
pino

FINITURA
pino superbianco

TIPO
tipo 2



TELAIO
standard



COPRIFILO
iscio



MANIGLIA
mendell 501



FAENZA

200FL



GRUPPO
base



CODICE
200FL

ESSENZA
pino

FINITURA
pino spazzolato
antico

TIPO
tpo 2



TELAIO
standard



COPRIFILO
sagomato



MANIGLIA
eloma country

ROMA

200FL6B



GRUPPO
base



CODICE
200FL6B

ESSENZA
noce

FINITURA
noce scuro

TIPO
tpo 1



TELAIO
standard



COPRIFILO
iscio



MANIGLIA
n.d.

AMERICA

100



Particolarmente ricca e curata in tutte le sue fasi di progettazione, lavorazione e rifinitura. Stipiti con capitello e finali che dona austerità all'insieme. Sfumature eleganti sulla base; una porta preziosa adatta ad introdurvi nell'angolo più importante della vostra casa. Una porta di gran classe.

Particularly rich of attentions in all its planning and working phases. It has doors jambs with capital and finals that give austerity at the door. A precious door with elegant shadings on the base; studied to introduce you in the most important corner of your house; a door of great class.

GRUPPO
100



CODICE
100

ESSENZA
toulipier

FINITURA
toulipier base
con sfumatura

TIPO
tipo 1



TELAIO
standard



COPRIFILO
liscio



ACCESSORI
capitello, finali
zoccolli



MANIGLIA
sirma derby



AMERICA

100



GRUPPO
100



CODICE
100

ESSENZA
rovere

FINITURA
rovere base

TIPO
tipo 1



TELAIO
standard



COPRIFILO
liscio



MANIGLIA
n.d.

ARIZONA

100-8B1



GRUPPO
100



CODICE
100-8B1

ESSENZA
rovere

FINITURA
rovere naturale

TIPO
tipo 1



TELAIO
standard



COPRIFILO
liscio



MANIGLIA
n.d.

ARIZONA

100-3B1



GRUPPO
100



CODICE
100-3B1

ESSENZA
castagno

FINITURA
castagno scuro
cas-001

TIPO
tipo 2 con bugna



TELAIO
standard



COPRIFILO
liscio



MANIGLIA
mandelli Sot

VIENNA

100-OPTQ



GRUPPO
100-C



CODICE
100-OPTQ

ESSENZA
toupier

FINITURA
toupier
laccato anticato

TIPO
tipo 1



TELAIO
standard



COPRIFILO
liscio



ACCESSORI
capitello



MANIGLIA
sloma vanity

VIENNA

100-OPTQ



GRUPPO
100-C



CODICE
100-OPTQ

ESSENZA
tulipier

FINITURA
tulipier laccato
pennellato

TIPO
tipo 1



TELAIO
standard



COPRIFILO
liscio



ACCESSORI
capitello



MANIGLIA
sirma country



POTENZA

200-OV



GRUPPO
100-O



CODICE
200-OV

ESSENZA
toulpier

FINITURA
toulpier mogano

TIPO
tipo 1



TELAIO
standard



COPRIFILO
liscio



MANIGLIA
mandelli Sori



MATERA

200-OV1V



GRUPPO
100-C



CODICE
200-OV1V

ESSENZA
toupier

FINITURA
toupier base
senza stamatura

TIPO
tipo 1



TELAIO
standard



COPRIFILO
fiscio



VETRO
satinato bianco
+ decoro

MANIGLIA
mandelli Sorì

PICCADILLY

100-C

CANTERBURY

100-C3B



GRUPPO
100-C



CODICE
100-C

ESSENZA
toulipier

FINITURA
toulipier base
con sfumatura

TIPO
tipo 1



TELAIO
standard



COPRIFILO
liscio



MANIGLIA
n.d.

Impostazione classica per questa porta con telaio e coprifiolo bombati: destinata a rimanere negli anni patrimonio della vostra casa. Una porta che aggiunge prestigio alle vostre soluzioni di arredo.

Classic formulation for this door with cambered frame and rounded staff: designed to last in the years as a patrimony of your house. A door that adds prestige to your solutions of furnishings.



GRUPPO
100-C



CODICE
100-C3B

ESSENZA
nochio

FINITURA
nochio base

TIPO
tipo 1



TELAIO
bombato



COPRIFILO
bombato



MANIGLIA
sistema vanity

LONDON

100-C3B1



Design importante per questa porta dove tradizione e modernità si fondono. Profili squadrati, rigorosi, impreziositi dalla testata a capitello che dona un tocco di austerità all'ambiente in cui ci introduce. L'invecchiatura extra conferisce un tocco di antico e di vissuto particolarmente pregevole.

Important design for this door where tradition and modernity are melted. Squared, rigorous profiles, preciously finished with a capital head that gives a touch of austerity to the atmosphere in which you are introduced. The extra aging confers the door a particular lived and old touch.

GRUPPO
100-C



CODICE
100-C3B1

ESSENZA
toupier

FINITURA
toupier invecchiato
extra

TIPO
tipo 1



TELAIO
standard



COPRIFILO
liscio



ACCESSORI
capitello



MANIGLIA
n.d.



Capitello con finale.
Capital and finials.



Telaio e coprifiло bombato color marmo.
Frame rounded marble color.



OLD CITY

700-C2B

LIVERPOOL

400-CTQ



Una porta che materializza in sé una perfetta sintesi tra linee classiche e moderne. Materiale di qualità arricchito dal processo di invecchiamento che dona un tono di vissuto a questa porta ricca e luminosa.

A door which a perfect synthesis between classic and modern lines. Best quality material enriched by aging process gives a lived look to this rich and luminous door.

Particolarmente luminosa e di personalità. Adatta a coloro che sono sensibili ad un certo fascino anglosassone: classicità insieme a modernità per questa porta british.

It's personal and luminous. Suggested for those who are sensitive to an Anglo-Saxon fascination; classic and modern style for this "british" door.



GRUPPO
100-C



CODICE
700-C2B

ESSENZA
tulipier

FINITURA
tulipier invecchiato
extra

TIPO
tipo 1



TELAIO
standard



COPRIFILO
liscio



VETRO
k glass

MANIGLIA
n.d.

GRUPPO
100-C



CODICE
400-CTQ

ESSENZA
alder

FINITURA
alder scuro

TIPO
tipo 1



TELAIO
standard



COPRIFILO
liscio



VETRO
cattedrale verde

MANIGLIA
n.d.

OXFORD

700-CTS

SIENATS

baseTS



Gusto Old England per questa porta tradizionale che richiama un po' la cultura anglosassone moderna. Luminosità con profili arrotondati e morbidi.

Old England style for this traditional door that recalls a little bit the modern Anglo-Saxon culture. Brightness with rounded and soft profiles.

GRUPPO
100-C



CODICE
700-CTS

ESSENZA
alder

FINITURA
alder scuro

TIPO
tpo 2



TELAIO
bombato



COPRIFILO
bombato



VETRO
satinato bianco

MANIGLIA
n.d.

Particolarmente curata nelle finiture, con questa vetrata che slancia la porta conferendole un tocco speciale di luminosità.

Really accurate in finishes, with this glass that hurl the door conferring it a special touch of brightness.



GRUPPO
100-C



CODICE
baseTS

ESSENZA
toulpier

FINITURA
toulpier base
con sfumatura

TIPO
tpo 1



TELAIO
standard



COPRIFILO
liscio



ACCESSORI
fini, zoccoli



VETRO
marmo bianco

MANIGLIA
n.d.

PORTA REI 30

FIAMMA

La certificazione rilasciata a garanzia dei valori tecnico-prestazionali pone la resistenza al fuoco della porta modello Fiamma nell'ordine dei 30 minuti (REI 30) e ottempera alle richieste di architetti, progettisti e consumatori attenti da sempre a fornire un prodotto di pregio in legno massello.

The certification issued as a guarantee of performance and technical merit puts the fire door model in the order of Fiamma 30 minutes (REI 30) and meets the requirements of architects, designers and discerning consumers always to provide valuable products in solid.



Serratura antipanico AGB OPERA con sblocco manuale istantaneo delle mandate, riscontro elettrico e nottolino libero/occupato.

OPERA AGB panic lock with manual release of instantaneous turns, and reflected electric cam free busy.



Cerniera registrabile autochiudente OTLAV.

Adjustable self-closing hinge OTLAV.



Nottolino libero/occupato.

Cam free busy.

PORTA REI 30

FIAMMA

Porta REI 30 con finitura Laccato Anticato e decoro floreale.

Door REI 30 with floral decoration.



Decorazione floreale.

Floral decoration.



PORTA A LIBRO AD ANTE UGUALI

TAORMINA LB2

La porta a libro ha i suoi punti di forza nella capacità di recuperare spazio senza interventi sulle parti murarie, con l'obiettivo primario di un minore ingombro, recuperando soprattutto negli spazi ristretti, spazio fisico.

The folding door is ideal for tight spaces, with the primary objective of a smaller footprint



Particolare libro simmetrica con serratura al centro.

Particular book symmetrical lockable center.



PORTA A LIBRO ASIMMETRICA

PUGLIA LB2A

La porta a libro è da sempre il prodotto ideale per l'installazione in spazi dove l'ingombro deve essere il più ridotto possibile, ed è quindi la versione a "libro asimmetrica" che compensa tale esigenza, con una porta molto simile, anche nella ferramenta, alle porte a battente standard.

The folding door has always been the ideal product for installation in spaces small, so it is the version to "book asymmetrical" that compensate for this need, with a door very similar to the doors standards.



Particolare libro asimmetrica con serratura e maniglia standard

Particular asymmetric book with lock and handle standard



MODELLI PORTE

Door models



Linea Base

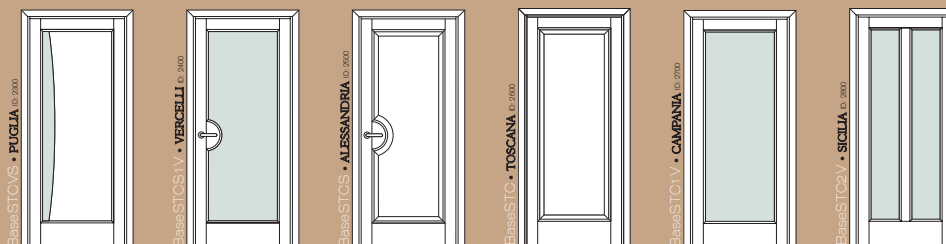
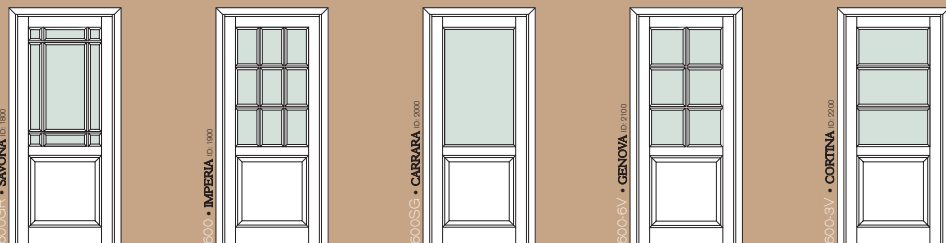

Linea BaseSTC

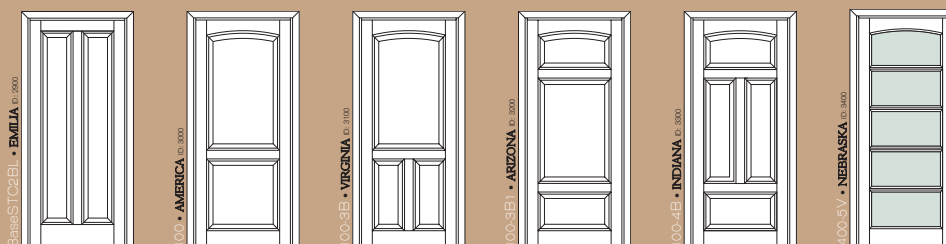

Linea 100



Linea 100STC

MODELLI PORTE

Door models



100-C3TC • NEW ENGLAND ID. 600



100-C3PJ • PICCADILLY ID. 600

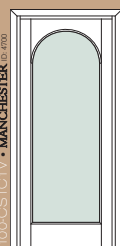

100-C3ST1V • MANCHESTER ID. 600



100-C4B • WINDSOR ID. 600



100-C3B • CANTERBURY ID. 600

Linea 100-C

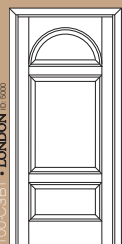

100-C3E1 • LONDON ID. 600

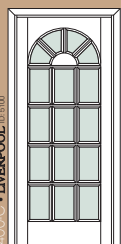

400-C3V • LIVERPOOL ID. 600



700-C2E • OLD CITY ID. 600



700-C3 • OXFORD ID. 600



700-C3G • DUBLINO ID. 600

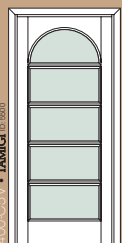

400-C3EV • TAMIGI ID. 600

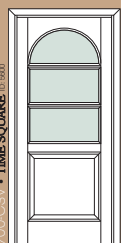

700-C3V • TIME SQUARE ID. 600

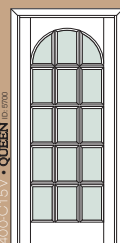

400-C3EV • QUEEN ID. 600



700-C3V • CAMBRIDGE ID. 600

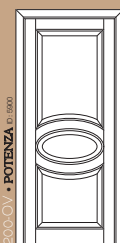

200-C3V • POTENZA ID. 600

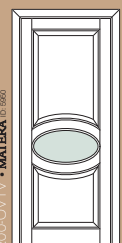

200-C3V • MATERA ID. 600

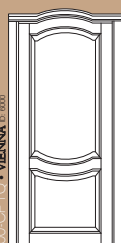

100-C3PT • VIENNA ID. 600

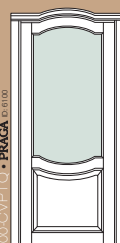

100-C3PT • PRAGA ID. 600

KIT DI MONTAGGIO ID. 7000

Disponibile per tutti i modelli di porte qui presentati.

Il numero dei pezzi dell'esempio qui di lato riportato, è puramente indicativo.

Il numero dei pezzi stessi varierà a seconda del modello di porta scelto. I vetri non sono mai inclusi nel Kit.

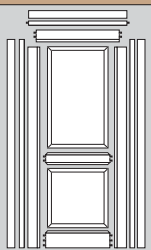

FINITURA GREZZA ID. 7100

VERSIONI DISPONIBILI

Versions available

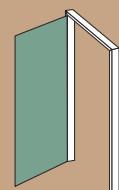

1. Porta a battente 1 anta
Single-wing leaf door

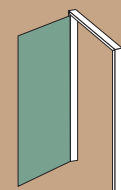

20. Porta a filo con cerniere a scomparsa
Flush door with invisible hinge

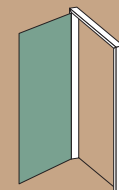

2. Porta a battente 1 anta a madonna
Single-wing leaf door with frame mounted on the outside of the wall

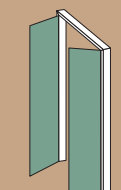

3. Porta a battente 2 ante
Double-wing leaf door

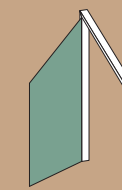

15. Porta diagonale
Diagonal door

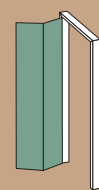

4. Porta a battente 2 ante incernierata centrale
Double-wing leaf door with central hinge

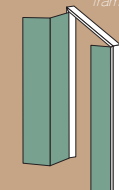

5. Porta a battente 2 ante incernierata centrale + fissa
Double-wing leaf door with central + fixed hinge



6. Porta a libro battente
Folding leaf door

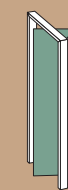

7. Porta a libro 2 asimmetrica
Asymmetrical folding door 2

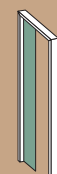

8. Porta scorrevole interno muro
Sliding door inside wall

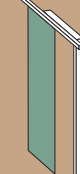

9. Porta scorrevole esterno muro
Sliding door outside wall

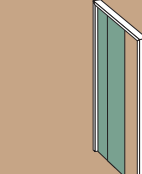

10. Porta scorrevole interno telaio
Sliding door inside frame

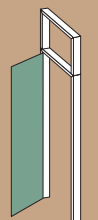

11. Porta con sopra luce apribile
Door with transom

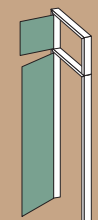

12. Porta con sopra luce apribile
Door with opening transom

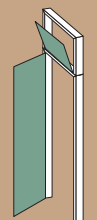

13. Porta con sopra luce apribile a wassistas
Door with pull-up opening transom

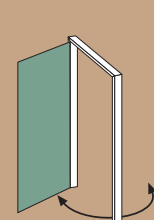

14. Porta a ventola
In-out swing door

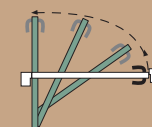

21. Porta rototraslante (*)
Rototranslating

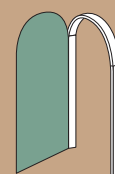

16. Porta ad arco
Round-arch door

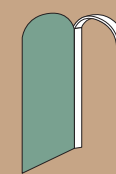

17. Porta ad arco ribassato (o su sagoma)
Lowered arch door (or to design)

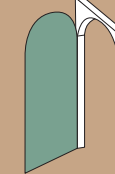

18. Porta ad arco tutto sesto tondo su quadro
Round-arch door in square frame

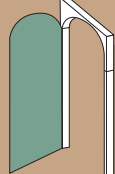

19. Porta ad arco ribassato (o su sagoma) tondo su quadro
Lowered arch door (or to design) in square frame

(*) CON TELAI COMPLANARE IL COPRIFILLO DOVRA' SPORGERE SUL LATO PORTA (limite presente solo con rototraslante a filo).

SCHEDE TECNICHE

Technical Datasheets

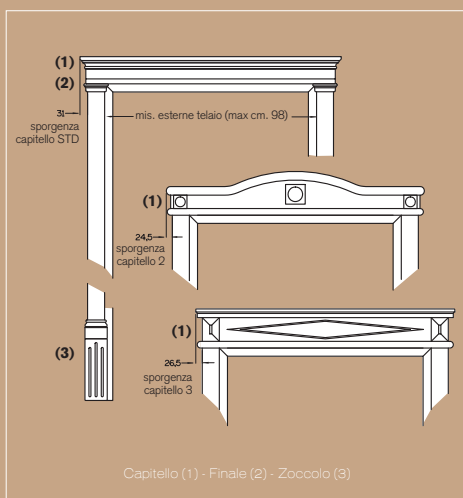
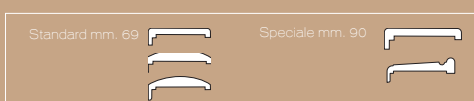
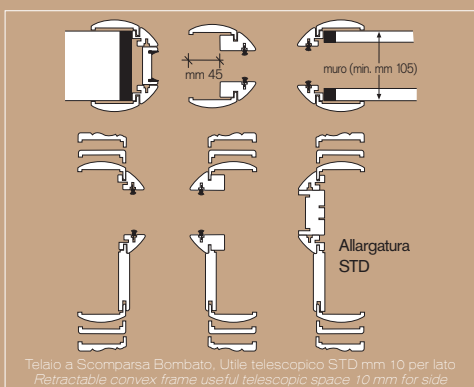
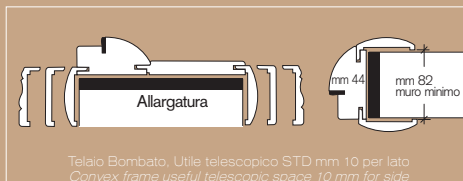
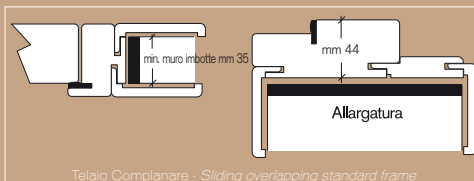
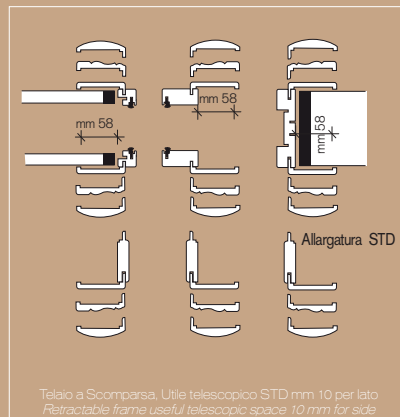
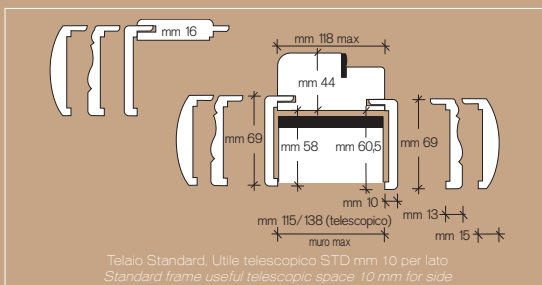
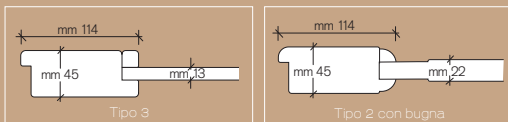
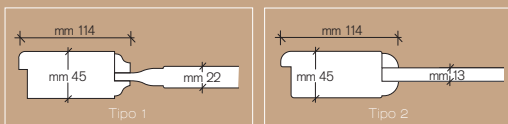

Riferimenti Misure (max est. telaio mm 980x2140)
References measures

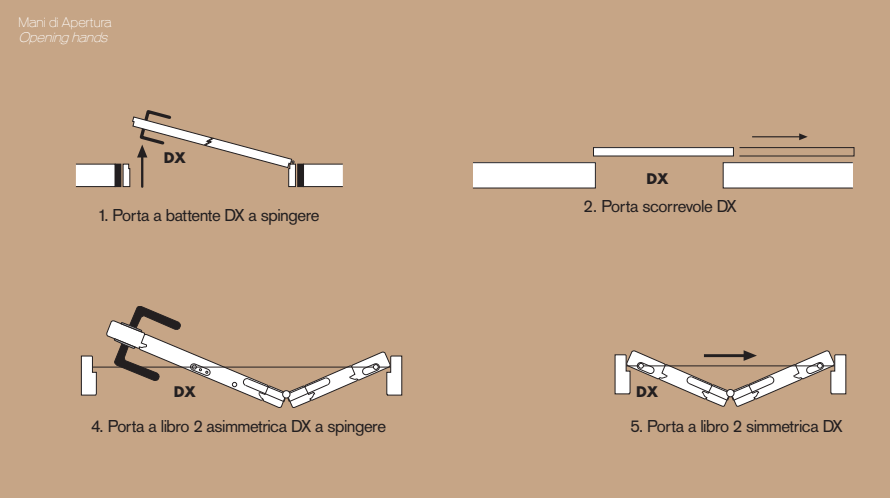
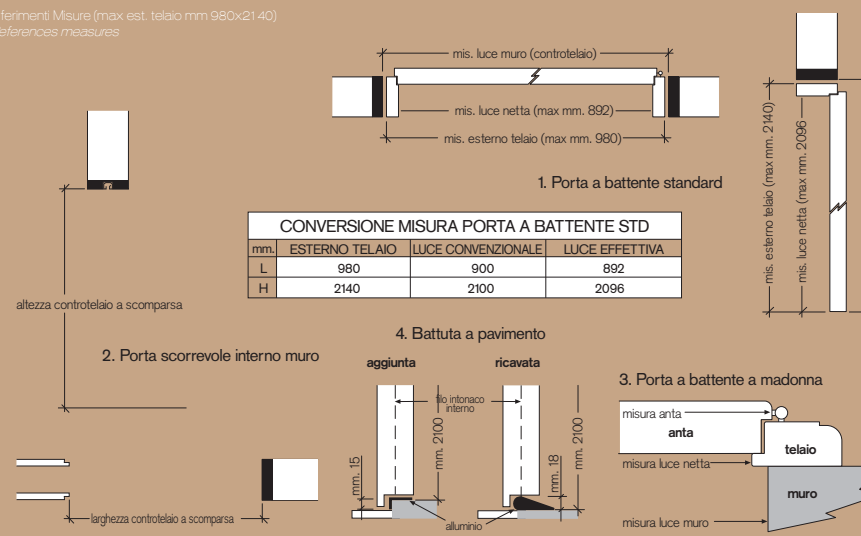

FERRAMENTA

Accessories

SUPPORTI VENDITA

Helper to choose the best



Serratura AGB con anubi barocco ottonate
(disponibile anche bronzato)
AGB lock hinges baroque brass
(also available in bronze)



Serratura AGB con anubi lisce, lunghe ottonate
(disponibile anche cromo satinato e bronzato)
AGB lock with hinges brass, smooth and long
(also available chrome and bronze)



Maniglia Bonaiti ottonata
(disponibile anche cromo satinato
e bronzato)
Handle Bonaiti brass
(also available in satin chrome
and bronze)



Serratura Bonaiti ottonata con chiave
(disponibile anche cromo satinato e bronzato)
Bonaiti spindle brass key version
(also available in satin chrome and bronze)



Serratura Bonaiti ottonata con nottolino
(disponibile anche cromo satinato e bronzato)
Bonaiti spindle brass nottolino
(also available in satin chrome and bronze)



SICMA VANITY ottonata/brass-plated



SICMA MIKI ottonata/brass-plated



SICMA SINCR0 cromata/chrome-plated



SICMA COUNTRY bronzata / bronze antique



SICMA DERBY cromata/chrome-plated



SICMA TOSCA ottonata/brass-plated



MANDELLI S91 ottonata/brass-plated

CATALOGO CLASSICO
CLASSIC CATALOGUE



CATALOGO MODERNO
MODERN CATALOGUE



MAZZETTA CLASSICA
CLASSIC WOOD FINISHES



MAZZETTA MODERNA
MODERN WOOD FINISHES



LISTINO
LIST



SITO INTERNET
INTERNET

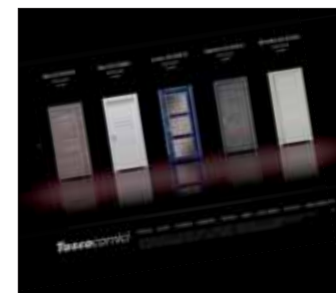

POSTER
POSTER



VETROFRANE
ADHESIVES



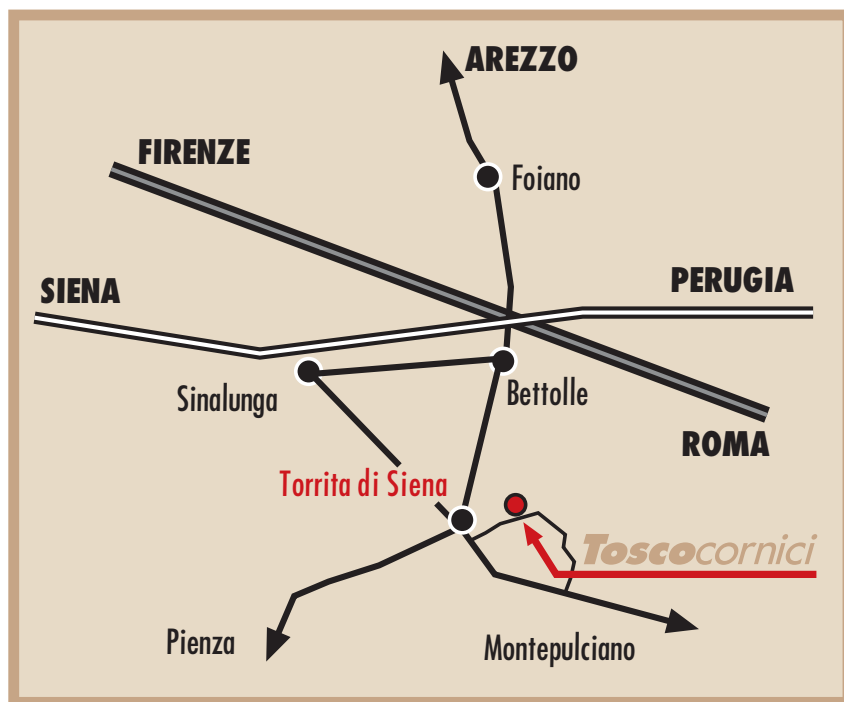

Toscocornici Porte® S.r.l.

Sede legale: Loc. Confinò, 100/101 - 53049 Torrita di Siena (SI) - Italy
 P. I 00242230522 - C.F. 00242230522 - Capitale sociale Euro 31.660,00
 Reg. Imprese di Siena n. 00242230522 - REA n. 67332
 Tel. + 39.0577.685426 - Fax + 39.0577.686429
www.toscocornici.it - info@toscocornici.it



